



Please wear appropriate eye protection!

**STW EZ1 CLCVR SS
STW EZ2 CLCVR SS,
AND STW EZ9 CLCVR SS
STEERING COLUMN COVER**

Cut or grind the column set screw head flush.



Slide cover over existing plastic cover until it seats against the bottom plastic cover.

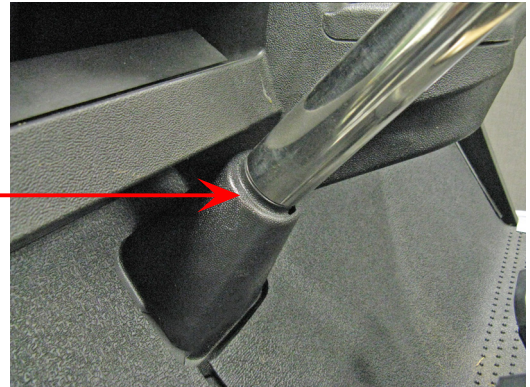

Steering wheel bottom cover should fit over the new column cover.

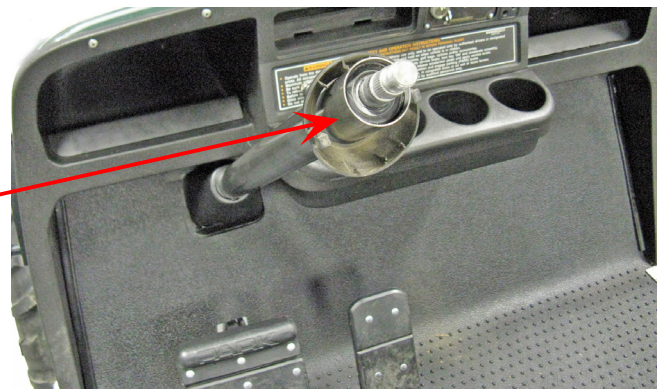

Steering Wheel Removal

Steering Wheel Removal

1. Remove the steering wheel by first removing the cover, then loosening the shaft nut but do not remove it.

NOTE: Leave the nut in place until the steering wheel is freed from the steering shaft. If the nut is removed, the steering wheel could injure you when it pops free.

2. Place your knees and arms under the steering wheel and brace your feet on the dash and rock the steering wheel back and forth (with great force) while pulling and pushing upward. In the rare occurrence the steering wheel will not come loose with this method, a puller (**Part #BU102061201**) will need to be used.

Steering Wheel Installation

1. Install the steering wheel onto the steering shaft, but do not install the nut.
2. Drive vehicle to determine if the wheel is correctly centered. if not, stop, reset the position and drive again to verify it is centered.
3. Install and tighten the steering wheel nut to 14 to 16 lbs.. **DO NOT OVERTIGHTEN!** Once a steering wheel has been overtightened, it is often destroyed trying to remove it again later.
4. Replace cover.

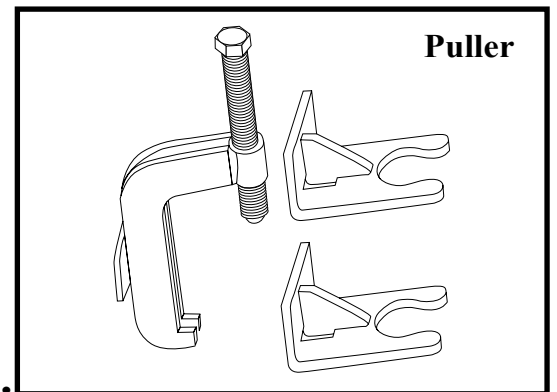

Caution: Wear the appropriate eye protection!

